

How to collimate the R200SS

First loosen all the three collimation “push” screws and tighten the other three collimation “pull” screws on the primary mirror cell completely to “reset” the primary mirror to a position where the primary mirror is placed closely to the mirror cell.

1. Remove the blue cap on the center of the four-vane spider to access adjustment screws for collimation. Loosen the fixing screw on the dead center of the spider to remove the secondary mirror holder with the mirror. There might be some washers on the center fixing bolt with which the secondary mirror holder is attached and please take care not to drop them onto the primary mirror.
2. Put a tiny dot at the center of the optical axis of the secondary mirror (offset 3.8mm from the center of the elliptical secondary mirror, refer to the Figure 2) by using a template below. A size of the dot should be about 1mm to 2mm in diameter.

Adjust to 68mm by enlarging or reducing a printed copy

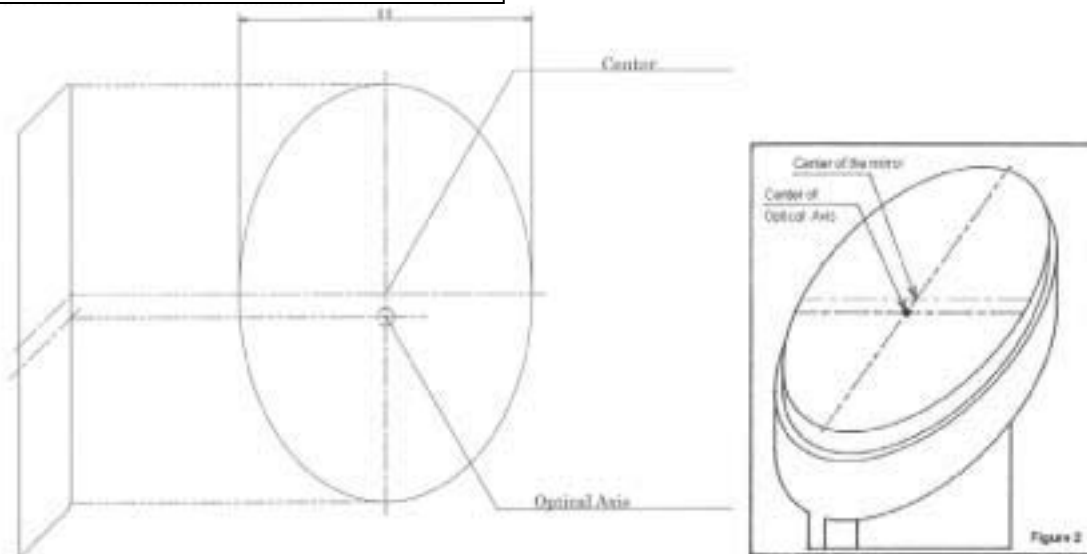

3. Return the secondary mirror holder with the mirror to the original place, and tentatively fix it with the fixing bolt lightly. At this stage do not touch the other three adjustments screws on the secondary mirror holder.
4. Draw a circle with diameter of 55mm on a black paper to make a disc. Open a pin hole of about 1mm to 2mm at the center of the disc. Cut out of the disc and place it into the change-over ring shown in the Figure 1.

How to collimate the R200SS

First loosen all the three collimation “push” screws and tighten the other three collimation “pull” screws on the primary mirror cell completely to “reset” the primary mirror to a position where the primary mirror is placed closely to the mirror cell.

1. Remove the blue cap on the center of the four-vane spider to access adjustment screws for collimation. Loosen the fixing screw on the dead center of the spider to remove the secondary mirror holder with the mirror. There might be some washers on the center fixing bolt with which the secondary mirror holder is attached and please take care not to drop them onto the primary mirror.

- 2 Put a tiny dot at the center of the optical axis of the secondary mirror (offset 3.8mm from the center of the elliptical secondary mirror, refer to the Figure 2) by using a template below. A size of the dot should be about 1mm to 2mm in diameter.
- 3 Return the secondary mirror holder with the mirror to the original place, and tentatively fix it with the fixing bolt lightly. At this stage do not touch the other three adjustments screws on the secondary mirror holder.
- 4 Draw a circle with diameter of 55mm on a black paper to make a disc. Open a pin hole of about 1mm to 2mm at the center of the disc. Cut out of the disc and place it into the change-over ring shown in the Figure 1.
- 5 Using a Sight tube or Cheshire eyepiece and attach it to the visual back of the focuser to look at the secondary mirror surface through the pin hole. You can see the dot on the secondary mirror shown in the Figure 3. Check if the dot moves up and down in the field of view of the pin hole when you move the secondary mirror holder to the left and right-hand direction a little. When it occurs, the dot may not be written in the center of the optical axis correctly. Return to the procedure 2.
- 6 Assuming that cross hairs are put in the field of view shown in the Figure 3, check which side on the vertical Y axis of the imaginary cross hairs the dot can be seen. If the dot is just on the line of Y axis, you can proceed to next step. If the dot is seen on the left-hand side, it means that the secondary mirror is somewhat distant from the primary mirror. If the dot is seen on the right-hand side, it means that the secondary mirror is somewhat close to the primary mirror. Please make sure that you return all the washers to the same place as they are.
7. Next, check which side on the horizontal X axis of the imaginary cross hairs the dot can be seen. If the dot is just on the line of X axis, you can proceed to next step. If the dot is seen above of the line, it means that the secondary mirror comes near the upper side shown in the Figure 5. In this case loosen the collimation screw "C" and tighten the screw "B" on the spider shown in the Figure 4. If the dot is seen below of the line, loosen the collimation screw "B" and tighten the screw "C" oppositely.
- 7 Confirm that the dot is seen at the center of the imaginary cross hairs in the field of view. Remove the disc from the change-over ring.
- 8 Rotate the secondary mirror holder so that each of distances "a" and "b" becomes equal shown in the Figure 6. Now fix the secondary mirror holder tightly.

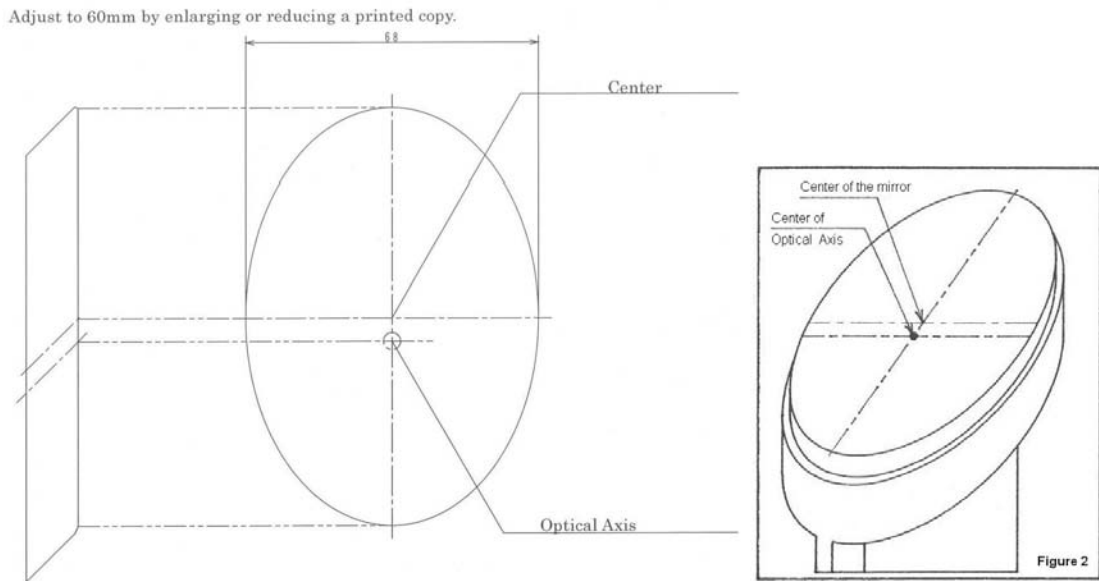

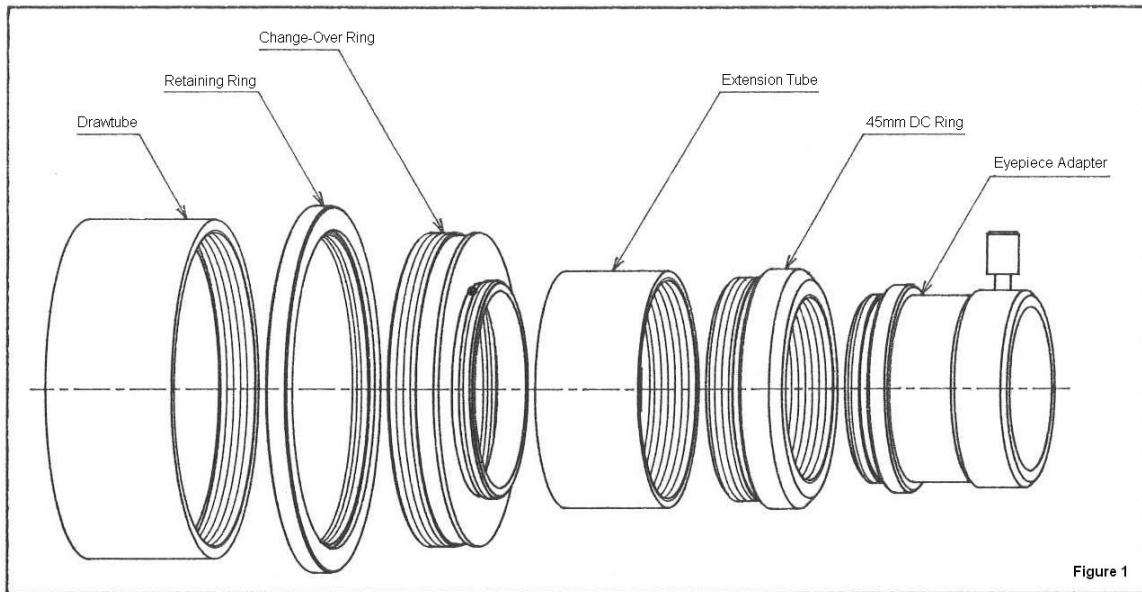

Figure 1

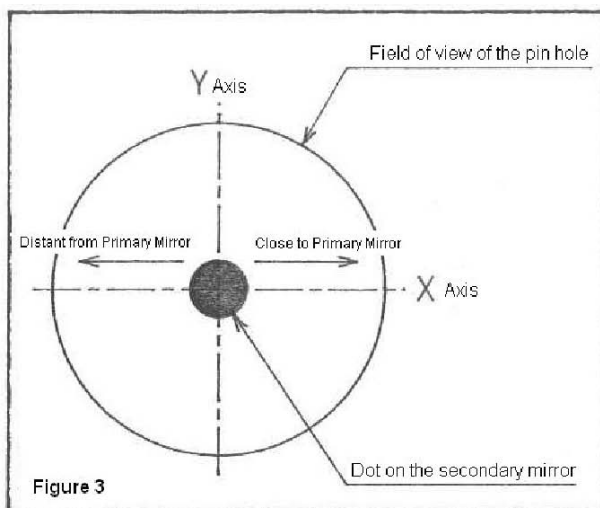

Figure 3

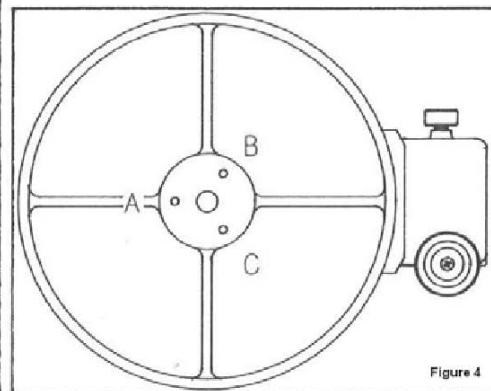

Figure 4

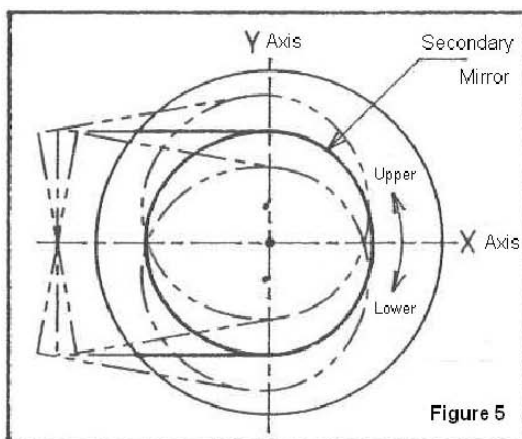

Figure 5

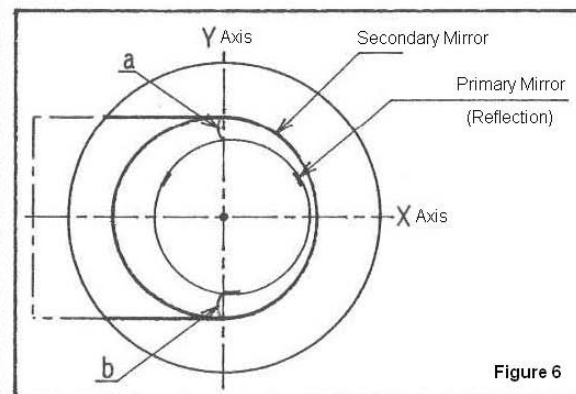

Figure 6

10. Again you need to adjust the position of the secondary mirror precisely with the collimation screws "B", "C" and "A". When you shift the secondary mirror upper or lower, turn the screws "B" or "C" only and don't use the screw "A". When you shift the secondary mirror forward, turn the screw "A". Turning the screws "A" and "B" evenly shifts the secondary mirror backward.

11. **Aligning the primary mirror:** When looking into the drawtube without attaching an eyepiece, you can see like the diagram below if the optical axis is correct. If you cannot see like the diagram, align the primary mirror with the collimation “push and pull” screws on the primary mirror cell.

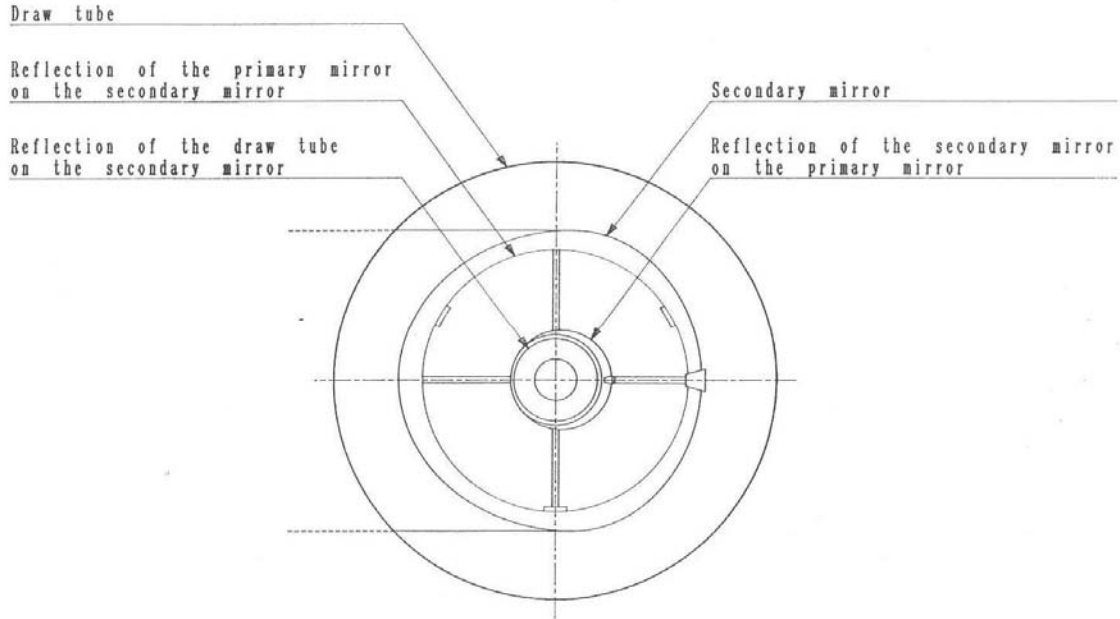

Figure 7

12. Finally a star test. Take the telescope outside and let the optics fully cool to the ambient temperature.